

SITE EXISTING TOPOGRAPHY

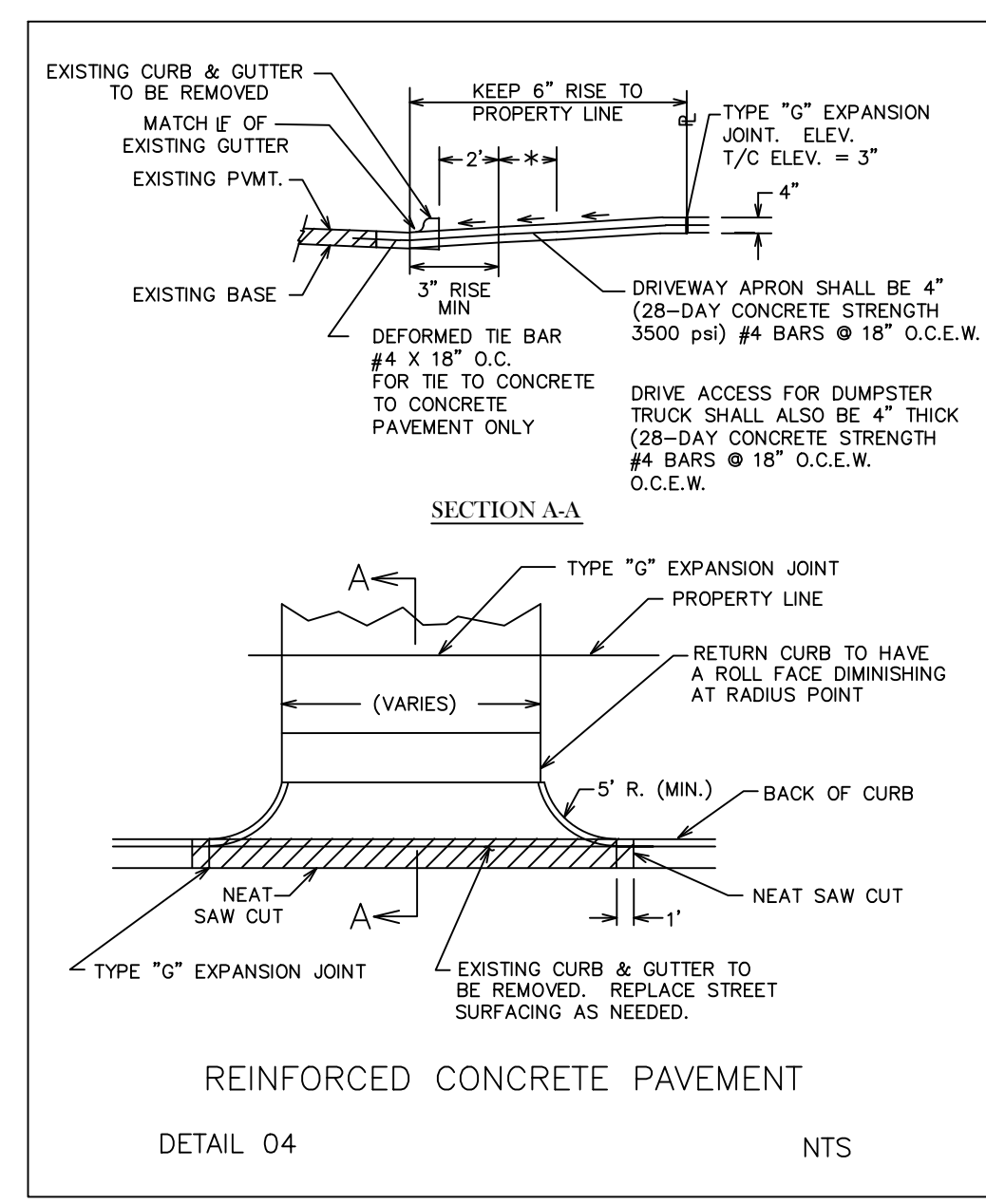

- NOTES**
- TYPE "B" CONTRACTION JOINTS SHALL BE INSTALLED 10' APART MAXIMUM.
 - TYPE "C" EXPANSION JOINTS SHALL BE SPACED 60' MAXIMUM.
 - THESE LOW RETAINING WALLS SHALL BE BUILT ALONG AND NOT MORE THAN 1.0' INSIDE THE EAST AND WEST BOUNDARIES OF THE PROPERTY, EACH BEING 85' LONG.
 - THESE RETAINING WALLS SHALL BE GRADED STARTING LEVEL WITH THE GROUND AT STA 0+00 AND REACHING MAXIMUM HEIGHT AT STA 0+85.

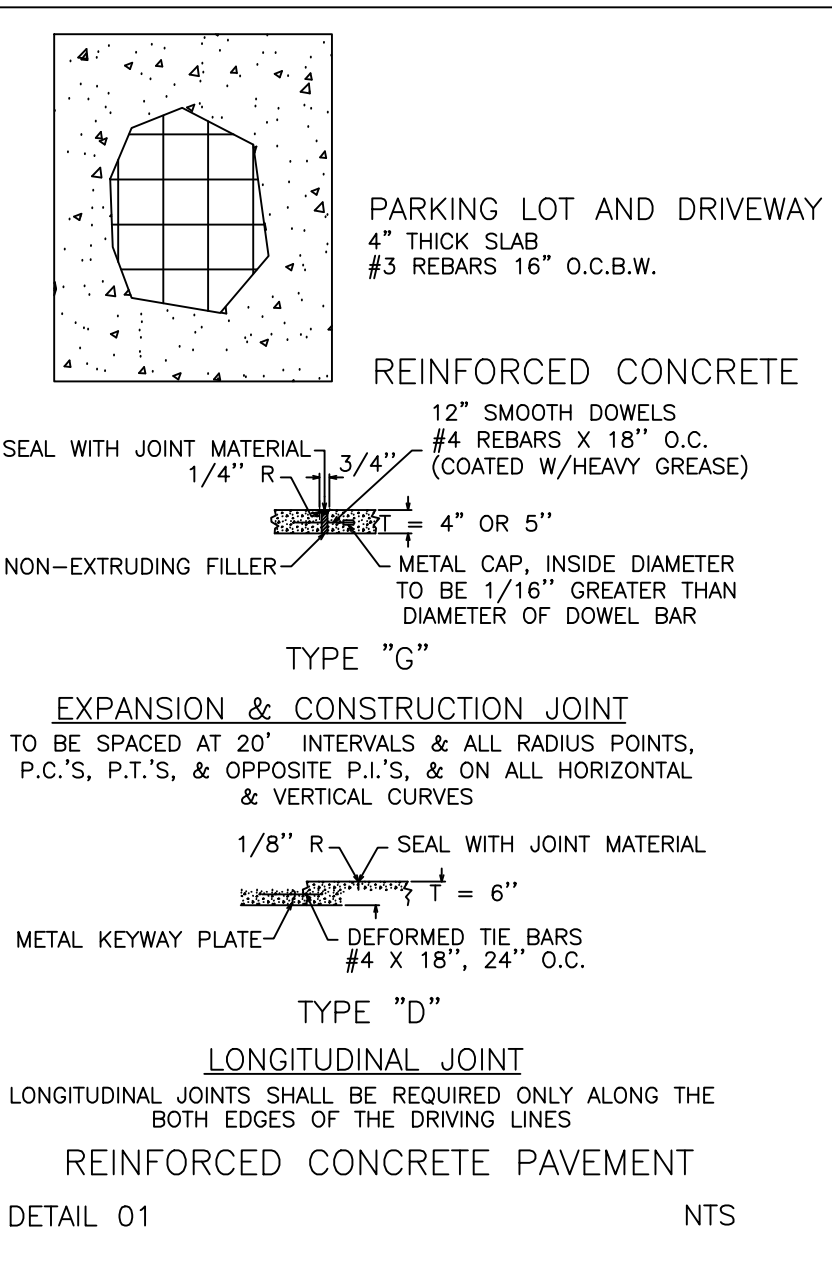
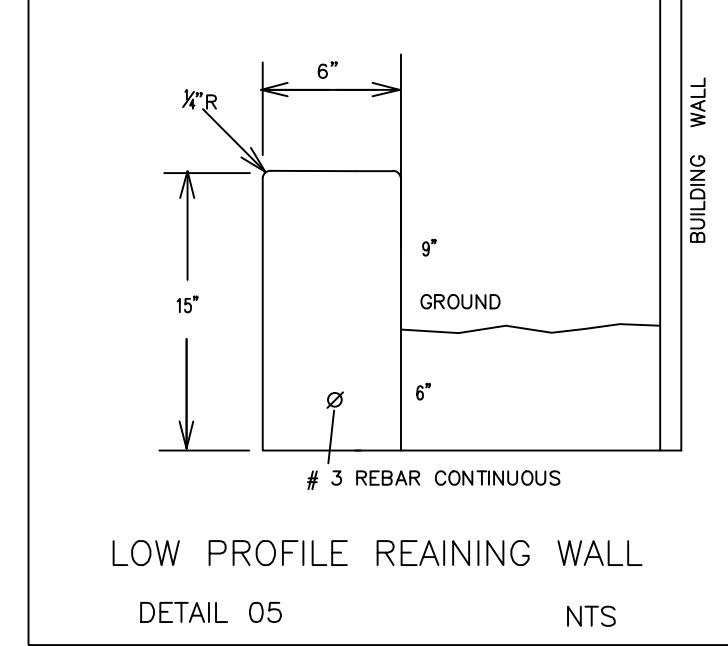

FLOOD PLAIN CERTIFICATION
NEITHER THIS TRACT NOR ITS PROPOSED IMPROVEMENTS LIE WITHIN A REGULATORY 100-YR FLOOD PLAIN PER FEMA PANEL 48041C0215F FOR BRAZOS COUNTY, TEXAS, DATED APRIL 2, 2014.

6-BUFFER LANDSCAPE REQUIRED (1)

AREA BUFFER STRIP 50'-WIDE = 8,100 S.F.
AREA BUFFER STRIP 35'-WIDE = 5,660 S.F.
BUFFER LANDSCAPE NEEDED = 2,440 S.F.
AT LEAST 50% CANOPY TREES = 1,220 S.F.

SYMBOL	SIZE	OFFICIAL NAME	#	UNIT	TOTAL
○	<3"	COTTONWOOD	5	250	1,250
○	<3"	POPULUS DELTOIDS (DELTPIDS)	7	100	700
○	<1.5"	CRAPMIRTLLE LAGERSTROEMIA	50	10	500
TOTAL					2,450

(1) WIDTH OF BUFFER STRIP BY STAFF REPORT APPROVING ZONING ORDINANCE NO. 2546 CHANGING ZONING FROM C-3 TO C-2.

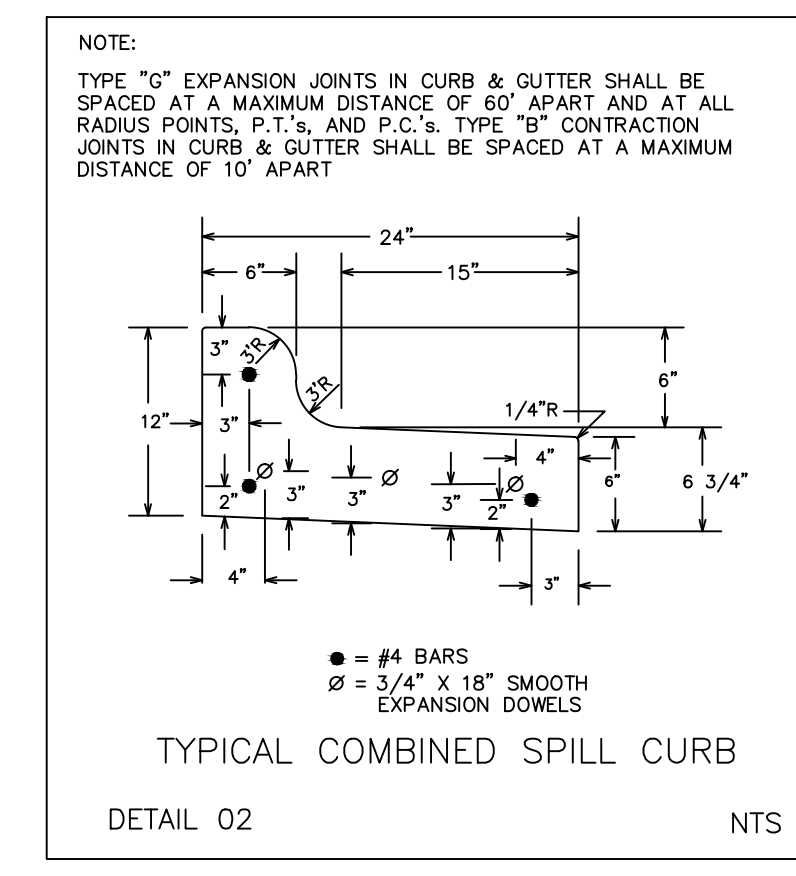
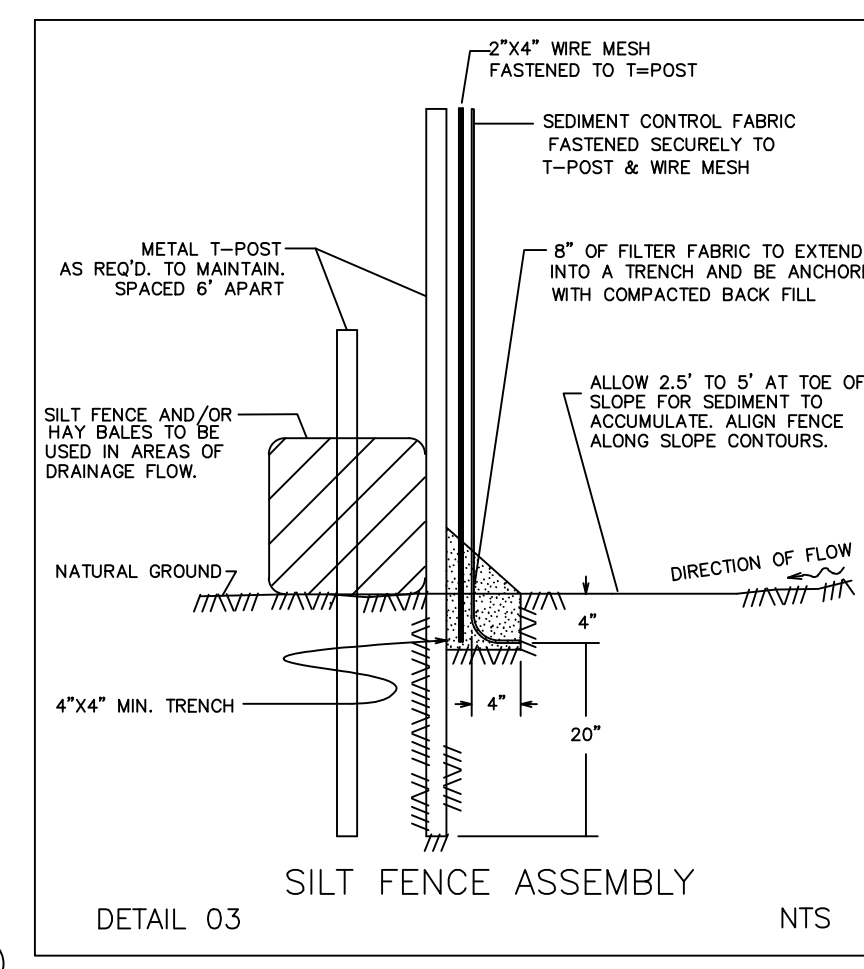

- 1-DEVELOPMENT NOTES**
- A 35'-WIDE BUFFER STRIP, REQUIRED BY ZONING ORDINANCE IS SET ALONG THE N.E. BOUNDARY.
 - THE WATER METER AND SERVICE LINE WILL BE RELOCATED 6' TO THE EAST OF THE PARKING LOT CURB.
 - SANITARY SEWER SERVICE WILL REMAIN UNCHANGED AT THE RIGHT REAR END OF THE PROPERTY AS HAS BEEN INDICATED BY THE WATER DEPARTMENT, COB.
 - CURRENTLY THERE IS ELECTRICITY AT THIS SITED, THERE IS NO NEED FOR A PUE OR FOR ADDITIONAL SERVICE.
 - IRRIGATION SHALL BE BY HOSE. ONE HOSE BIB SHALL BE INSTALLED HALF THE DISTANCE OF THE 1" SERVICE GOING INTO THE BUILDING.
 - LANDSCAPING FOR THE 3'-WIDE STRIP ADJACENT TO THE WESTERN PROPERTY SHALL CONSIST OF A 3" GRAVEL LAYER SET ON IMPERVIOUS PLASTIC SHEETING.

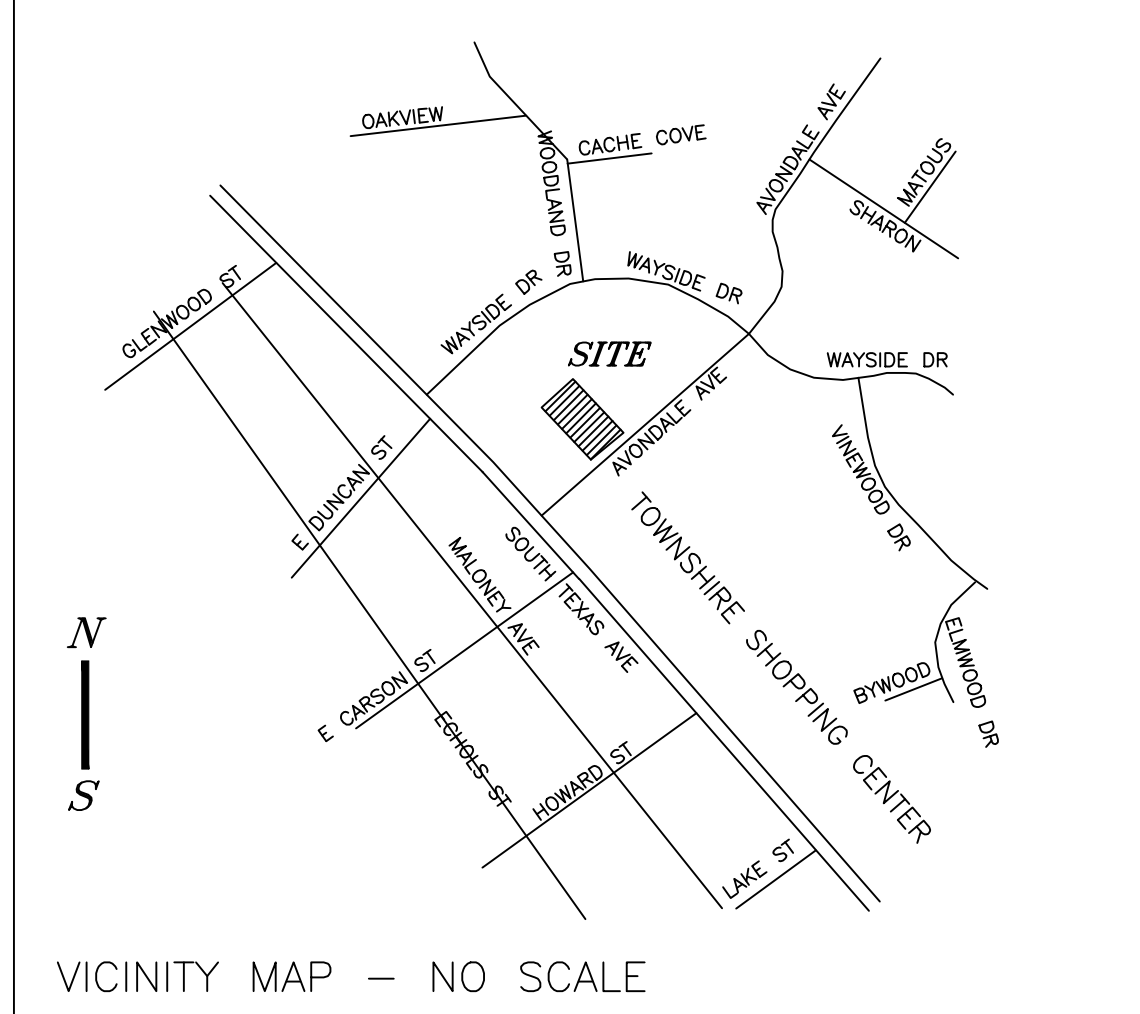

- 2-EROSION AND SEDIMENT CONTROL**
- BEST MANAGEMENT PRACTICES SHALL BE FOLLOWED TO PREVENT EROSION AND SEDIMENTATION FROM DISTURBED SOIL. TO THIS EFFECT THE FOLLOWING DEVICES SHALL BE INSTALLED:
- A SILTING BARRIER ALONG THE LOWER ENDS OF THE LAND BEING DISTURBED. THIS BARRIER WILL REMAIN IN PLACE UNTIL STABILIZATION OR REVEGETATION OCCURS. SEE DETAIL 03.
 - A CONSTRUCTION ENTRANCE A MINIMUM OF 12'x50' CONSISTING OF ROCK-RUBBLE WITH PIECES 1-1/2" TO 3-1/2" IN DIAMETER.
 - ALL STORM DRAINAGE INLETS SHALL BE PROTECTED DURING CONSTRUCTION, UNTIL REVEGETATION OR STABILIZATION IS COMPLETE. FROM RUNOFF SEDIMENTATION BY A 6"-HIGH BARRIER MADE UP OF 20-LB STRAW FILLED BURLAP BAGS (OR EQUIVALENT BARRIER). BARRIERS SHALL BE CLEANED AS SOON AS THEIR CAPACITY HAS BEEN REDUCED BY 50%.
 - A LOCATION WITHIN THE PROJECT AREA AND NEAR ITS ENTRANCE SHALL BE IDENTIFIED AS A TRUCK WASH OUT AREA.
 - A LOCATION WITHIN THE PROJECT SHALL BE IDENTIFIED AS ON-SITE STORAGE OF CONSTRUCTION WASTE MATERIALS SUCH AS BROKEN CONCRETE, CONCRETE WASHOUT, WOODEN FORMS, ETC.
 - WIND BLOWN MATERIAL SHALL BE CONTAINED WITHIN THE PROJECT AREA AND DISPOSED OF WITH OTHER PROJECT WASTE.

- 3-BOUNDARY NOTES:**
- ALL LINEAR DIMENSIONS ARE IN FEET UNLESS OTHERWISE NOTED.
 - ALL CALLS ARE MEASURED CALLS.
 - BEARING SOURCE IS THE PLAT OF CULPEPPER MANOR, 1ST INSTALLMENT, RECORDED IN 169/289.
 - BASE LINE IS NOTED WITH * * *
 - RESTRICTIONS IN 104/540, 142/39 & 242/507.
 - FRONT BL 30' PER IN 242/507.
 - BM1 ELEV. 300' IS ASSUMED.
 - SPOT ELEV. PRECEDED OR FOLLOWED BY A + SIGN ARE TOP OF CURB.

- 4-LEGEND**
- IR = IRON ROD
 - GM = CONCRETE MARKER
 - 4473 = MARKER LICENSE
 - S/F = SET/FOUND
 - ROW = RIGHT OF WAY
 - BOC = BACK OF CURB
 - BB = BACK TO BACK OF CURB
 - BL = BUILDING LINE
 - PUE = PUBLIC UTILITY EASMT.
 - OIE = OVERHEAD ELECTRIC
 - GM = GAS METER
 - WM = WATER METER
 - WV = WATER VALVE
 - S- = SANITARY SEWER
 - W- = WATER LINE
 - FH = FIRE HYDRANT
 - BM = BENCH MARK
 - - - - - RUNOFF FLOW DIRECTION

- 5-PARKING ANALYSIS**
- C-2 ZONING, RETAIL, 1PS FOR 250 GFA:
3,010 SF/250 = 12 PARKING SPACES
11 PARKING SPACES WILL BE 9.5'x20',
1 HANDICAP SPACE WILL BE 15'x20'.

ALINDO ENGINEERS AND PLANNERS, INC.
3107 ROLLONG GLEN BRYAN, TEXAS 77807 979-846-8868
FIRM LICENSES: ENGINEERING F-1799, SURVEYING 100269-00

OWNER/DEVELOPER:
KYLE HAN AND SUNG LEE
1103 MISSION HILLS DR.
COLLEGE STATION, TX 77845
CELL: 979-436-4241
eMAIL: kylehan4241@gmail.com

PROPOSED IMPROVEMENTS

S BEAUTY SITE PLAN
508 AVONDALE AVENUE

BCAD # 49850
0.4287 ACRE (18,675 SF) TRACT
PART OF LOT 7 AND PART OF LOT 6, BLOCK A
CAVITT'S WOODLAND HEIGHTS
BRYAN, BRAZOS COUNTY, TEXAS

DATE:	MAY 12, 2022	PROJECT	7-22
APPROVED BY:	CAG	SHEET	1 of 1
REVISIONS:	JUNE 14, 2022		